

No. 131-A MONITOR AMPLIFIER

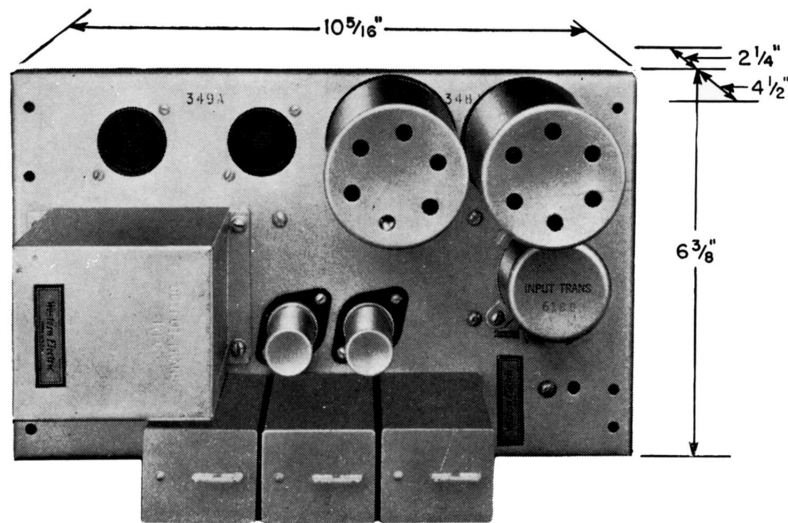

Figure 23 — 131A Monitor Amplifier.

Use — This amplifier is a compact single unit, especially designed for AM and FM studio-booth monitoring applications where the control booth operator requires a means for program cueing to performers in an associated studio or to remote pick up lines. A booth and two studio loudspeakers, as well as line cue-feeding circuits, can be served from its output network.

Description — The 131A Amplifier is of the two-stage push-pull type and possesses adequate gain to operate either from the output of a single preamplifier or to be bridged across the output of a main amplifier.

Output power is sufficient to satisfy normal booth and studio requirements. Taps are provided on the output transformer which permit adjustment to work into impedances from 1 to 1200 ohms, thus assuring high quality performance over a wide variety of loudspeaker impedance combinations. The unit is constructed for operation from an external power supply source.

Each of the three loudspeaker branch circuits is provided with a cut-off relay which may be connected to operate from microphone or talkback keys so that switching a microphone on, will at the same time, automatically silence the associated loudspeaker. This feature is desirable where microphone and loudspeakers are located in the same room since it offers a safeguard against acoustic feedback or "singing" which is likely to occur when a microphone is exposed to sound from a loudspeaker connected to the same amplifier channel.

Power for operating the relays is obtained from the power stage cathode circuit of the amplifier so that a separate relay power supply is not required.

Features

- Excellent for studio-booth monitoring.
- Variety of application.
- Cut-off relays — for loudspeakers.
- Tapped output transformer to permit working into impedances from 1 to 1200 ohms.
- Stabilized feedback.

Specifications

Frequency Response: Uniform within ± 1 db over the range 50 to 15,000 cycles.

Output Noise: -55 dbm unweighted, with maximum gain.

Signal-to-Noise Ratio: 80 db under conditions of normal gain and output level.

Source Impedance: 600 ohms matching. For bridging add proper input pad.

Load Impedance: Tapped output transformer provides for operation into any impedance from 1 to 1,200 ohms.

Maximum Gain: 50 db.

Output Power: 3.2 watts (+35 dbm) with 1 per cent harmonic distortion; 5 watts (+37 dbm) with 5 per cent harmonic distortion.

Power Supply: Filament 6.3 volts, 3 amperes a-c or d-c; plate 275 volts, 75 ma., d-c. (18 or 20 Type Rectifiers recommended for power supply).

No. 131-A MONITOR AMPLIFIER

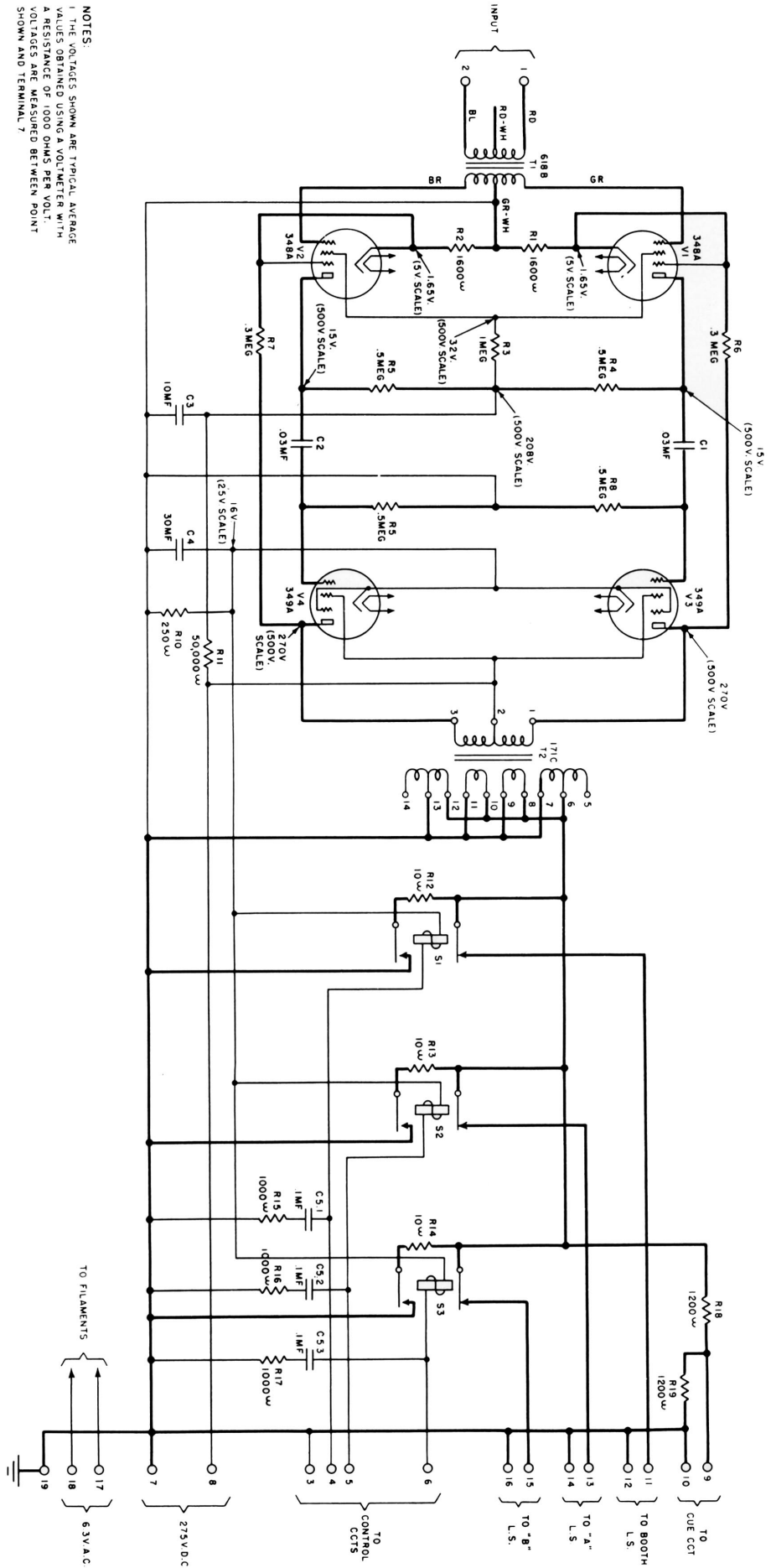

FIG. 1 — Schematic